

AIXM Change Management

May 4-6, 2010

AIXM/WXXM
Conference | 2010

Navin Vembar
Aeronautical Information Management (AIM)
Federal Aviation Administration



Overview

- Objective
- AIXM Change Management
 - Processes
 - CCB
 - Tools
 - AIXM Version Control



Objective

- Need to stabilize AIXM's change after the AIXM 5 “big-bang”
 - Model stability leads to system stability
- Codify the process behind those changes
- Ensure that stakeholders are more formally consulted and all their issues are addressed
- The presentation covers a *CM proposal*

A mature model needs mature maintenance processes



AIXM Change Management

- AIXM 4.5
 - formal, but with limited representation Change Control Board
- AIXM 5.0/5.1
 - done by FAA/EUROCONTROL Design Team
 - With support from NGA and some European States
 - Informal consultation through AIXM Forum
- Need additional formalism
 - Need a CCB to involve more stakeholders in the decision making



The Change Control Board Will...

- Consist of members who are representatives of stakeholder groups
- Ensure visibility and extend the ability to contribute in the change management process to all AIXM stakeholders
- Maintain separation between Model maintenance and Specification/Guidance Material approval
- Be responsible for the AIXM-associated documentation

EUROCONTROL and FAA will provide and maintain the infrastructure for the CCB process and the AIXM maintenance.



AIXM Stakeholder Groups

- States
- ANSPs
- Flight Plan and Air Service Providers
- Airspace Users and Airlines
- Airports
- Manufacturing Industry
- Military
- EUROCONTROL and FAA



CCB Process

analysis AIXM Change Management Process

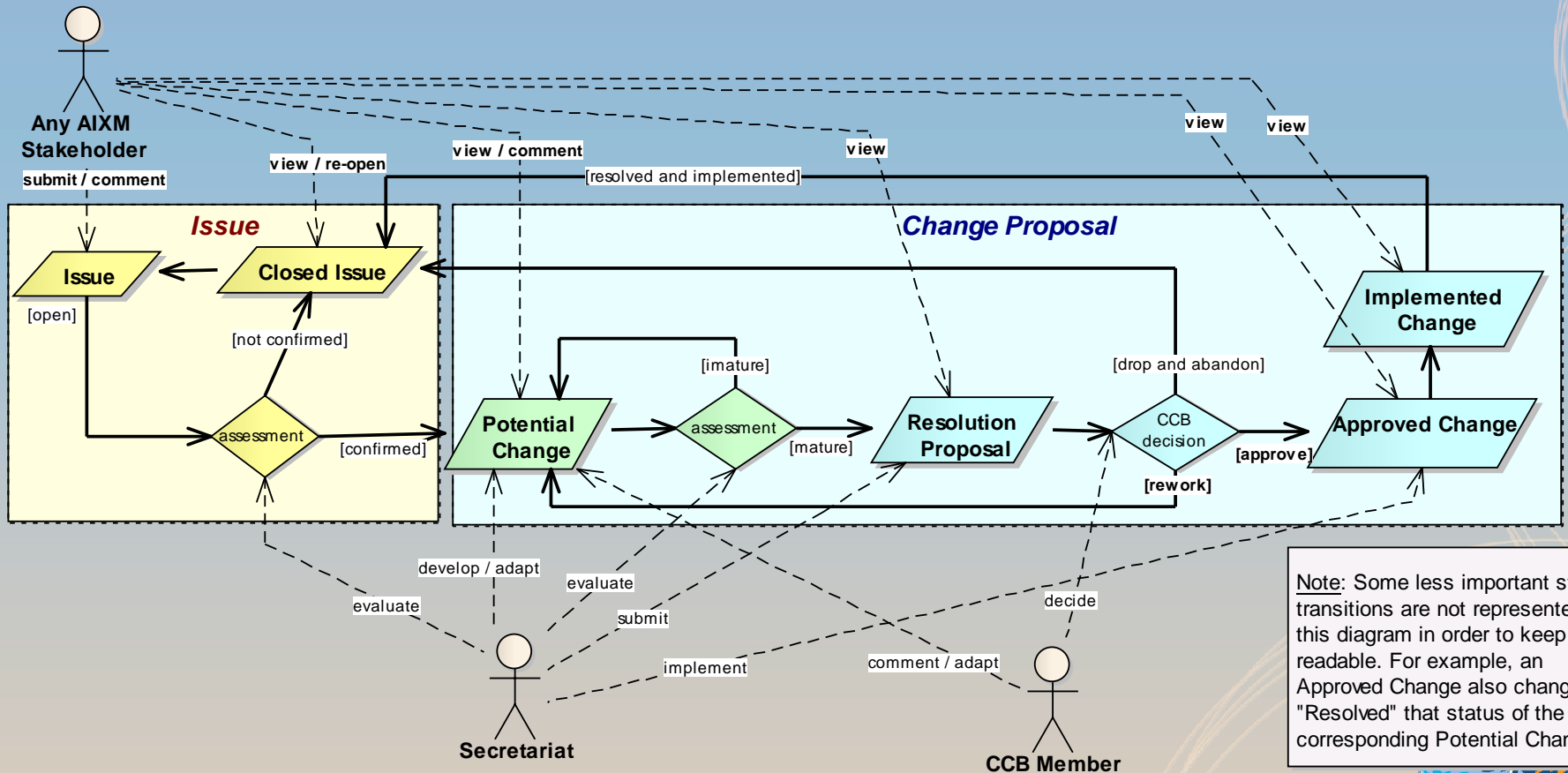

Note: Some less important state transitions are not represented on this diagram in order to keep it readable. For example, an Approved Change also changes into "Resolved" that status of the corresponding Potential Change.



Connection to Derived Standards

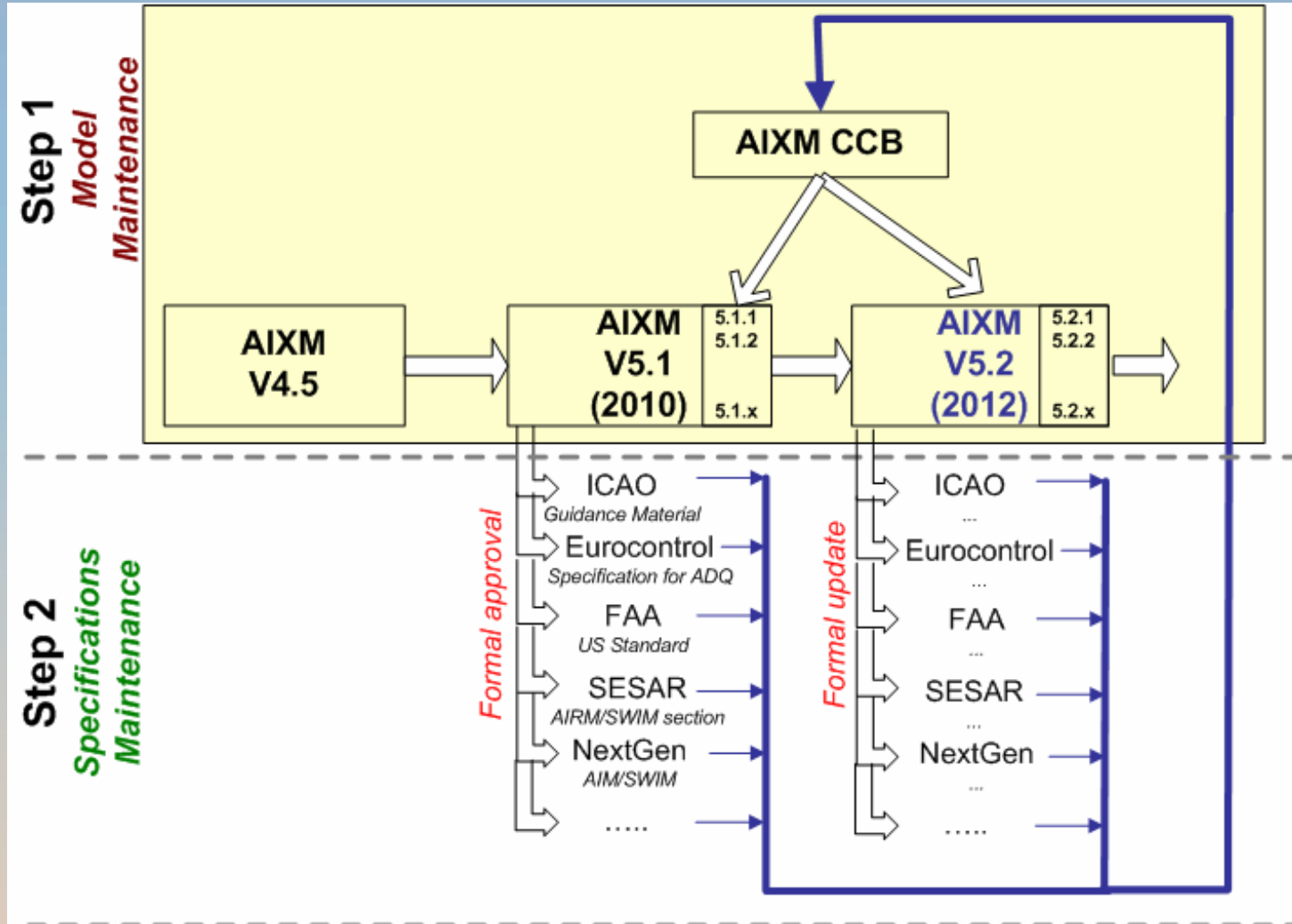

Issue and Change Tracking

- Using the open-source JIRA Tool
 - Hosted by the FAA
- All issues will be tracked through completion through the tool
- Must be registered with the Change Tracking system to create issues
 - Any stakeholder may do so



AIXM Version Management

- Need to clearly delineate what changes in versions may entail
- Mitigate system development risk by controlling the severity and frequency of changes
- Three types of changes
 - Major Changes
 - Intermediate Changes
 - Minor Changes



AIXM Version Control

- Major changes
 - Conceptual change
 - Cannot mechanically convert from prior version
 - Every 5-7 years
 - Changes major number of release
 - AIXM 4 -> AIXM 5



AIXM Version Control

- Intermediate Changes
 - Additions to the model
 - Changes to structure
 - Two-way mechanical conversion between prior version via XSLT and extensions of the prior version
 - No capabilities will be removed
 - Every 3 years (AIXM 5.2 scheduled for 2012)
 - Changes intermediate number of release
 - AIXM 5.1 -> AIXM 5.2



AIXM Version Control

- Minor release
 - Bug fix release
 - Fixes to spelling
 - Fixes to UML which do not affect schema
 - Fixes to definitions
 - No additions of features, objects, or relationships
 - Mechanical two-way conversion through XSLT
 - Change to minor version of release
 - AIXM 5.1.0 -> AIXM 5.1.1



Conclusion

- Promoting both openness and formalism in the change management process
- Mitigating the risk of system development against a changing standard

